

delve

JAN 2022 V22

*Cover Photo: Penn State
Health Medical Facility*

**Future-Proofing
With Stylex**

**Delving Into The
Public Sector**

**Stepping Into the
Future of Contract
Design**

**STRIKING LIGHTING INSTALLATION BY LODES
TAKES CENTER STAGE IN NEW**

**PENN STATE
HEALTH MEDICAL FACILITY**



Rise.



The chair Elevated.

via
SEATING

viaseating.com

contents

JAN 2022 V.22

STEPPING INTO THE FUTURE
BY SUSAN MULHOLLAND03

MRL'S PRODUCT ROUND UP
A FEW OF OUR FAVORITES05

FUTURE-PROOFING SEATING
WITH STYLEX07

**DELVING INTO THE PUBLIC
SECTOR** WITH MICHELLE WARREN10

SCENERY WINS GOOD DESIGN
WITH ARCADIA12

**PENN STATE HEALTH MEDICAL
FACILITY** WITH LODES15

**IMPLICATIONS OF A GLOBAL
PANDEMIC** BY ASHLEY BLEVINS19

MRL TEAM NEWS
HEIDI FIELDS21

KEEPING CONNECTED
REP GROUPS OUT AND ABOUT22



Susan Mulholland discusses her career in the design world, and what she hopes newer designers can learn from her experience.



Arcadia's Scenery Modular Collection wins the Good Design Award.



COVER STORY: Striking lighting installation by Lodes takes center stage at Penn State.

ADVERTISE WITH MRL



My Resource Library
is the best way to reach
the Contract Design Industry
with your message!

Learn about all of the
unique advertising options
now offered by MRL.
Our team will help guide
you to build a personalized
advertising plan that
will help you meet your
advertising goals!

LEARN MORE

editor's note

Dear Reader,

As this new year begins, we look ahead to what the future may bring to our diverse industry, and consider how we might answer the challenges of the future.

From design to manufacturing we are highlighting different perspectives and solutions.

While we can't predict the future, we can predict that whatever this year may hold, our industry will face any challenges with a fresh, innovative attitude and commitment to excellence.

It's an exciting time to be a part of the Contract Design Industry. We invite you to dive into this issue of Delve Magazine!

Enjoy!

Do you have an idea for an article in Delve? We want to hear from you! Send us and email at...

industrynews@myresourcelibrary.com.



**THE
MY RESOURCE LIBRARY
FAMILY**



Stepping Into the FUTURE of Contract Design

BY SUSAN MULHOLLAND

Our natural tendencies are to look ahead and make predictions as we begin a new year. Sometimes these predictions are based on what we know as absolutes, sometimes they are based on statistics and other metrics that have been gathered and analyzed from the previous year, or they are just occasionally lucky guesses that turn out to be more accurate because they are based on something that can't be measured- our intuition.

Contract design has been in a consistent state since its inception. Most notably is office design or workplace design. Because it relies on consistencies that keep it humming on that trajectory. Task chairs, guest chairs, work surfaces, file cabinets, worktables, and conference room furniture are always in the mix. Lobbies that have reception desks and lounge furniture fill out the list. If you have been doing this work as long as I have, you could also add systems furniture. Office planners and facilities managers are familiar with the manufacturers who provide these products. They are aware of the price, the quality, and how to maintain them. They have developed solid relationships with manufacturers and furniture dealers that have helped them keep their workplace interiors running smoothly for years and sometimes decades. But this uninterrupted flow is now being disrupted.

Why? Because we all know that the past two years have changed everything we think about when it comes to work. Office spaces are not occupied, and workers are rethinking where, when, and how they do their jobs. So, where does that leave an industry that has relied so heavily on a particular pattern of behavior to survive?

The contract industry has the once-in-a-lifetime opportunity to truly make a difference in how we view our workplaces. Now is the time for contract interior designers to lead the way.



Susan Mulholland

Susan Mulholland studied interior design at Northern Arizona University and is an NCIDQ certificate holder. She has 30 years of interior design experience in commercial design. Her experience in the industry covers a large variety of projects that focus on workplace, healthcare, and hospitality. Her design studio Mulholland Art & Design Commercial Interiors is in Tucson, Arizona, where she has been helping clients for the past 20 years. [Connect with Susan Mulholland on her website.](#)

I have to admit; I am an eternal optimist. With my rose-colored glasses, I see interior designers, regardless of what type of design you do as the creators of great things, we are always looking for ways to enhance the buildings we humans inhabit. Our buildings' walls, floors, and ceilings are what we use as a starting point for our best work. Design is about function and embellishment. Let's take what we think of as great design—whether it is a piece of furniture, light fixture, or flooring material and put it in any room in any building. We are creating an identifiable interior space. This is what the essence of interior design is—defining interior space for a particular use.

Working, living, and playing all have been mashed together. Our ideas of defined spaces for a specific purpose have also been mashed. If you think about that, not from the perspective of a pandemic, but from the perspective of living, then every space we use needs to be driven by the need to be flexible and multifunctional.

Students looking to enter the field and designers who are new to the profession will need to understand that contract design is not just about how many chairs and worksurfaces you can get into a space or the best circulation pattern to maximize the square footage of a building. With the current state of all types of work and professions under scrutiny, interior designers especially contract interior designers, need to rethink the definition of contract design. We need a new definition that addresses the thought process of what contract interiors could be.

Residential, retail, education, hospitality, and healthcare designers will need to understand that their specialties will be required for designing the workplaces of the future. Workplace designers who only work in offices need to think like designers do who work in these specialties. The reason is that we are working in all of these environments. Workplace design needs to have furniture, finishes, and accessories as well as a thought process that designers use when designing spaces not typically defined as an office. We need to think about all of our interiors holistically, emphasizing health and wellbeing regardless of the task or intent of the space. Human-centric design needs to transcend healthcare and move into all areas of the built environment.

This also means that interior design is more than just what you can do on a computer. Interior Design computer programs have evolved tremendously in the past twenty years and in the past five years, even more so. Designers who come out of school now are being asked to be proficient in them. But that isn't design; that's being technologically verse. When we are infants, we learn how to crawl before we walk or run; designers need to be able to design without the help of a computer or an app. This means understanding that although most design these days requires knowledge outside of just being able to "put a room together," it also requires the sensibility of a craftsman as well as a technician.

This became highly noticeable during the pandemic. Designers who had good design skills outside of just knowing how to use a particular drafting program were able to work in various design niches. Residential design, in particular, became a hot spot for entry-level positions because of the amount of work available. Too often, designers who work in contract or office design are labeled as boring or less artistic because they are focusing on building codes, product performance, and durability instead of the overall room aesthetics. Because color theory and design composition are not part of what they do daily, they are viewed as less diverse, not creative, and more technically dependent on software to do their job.

I don't see it this way. Any type of interior design incorporates everything from the overall design composition and aesthetics to understanding the building or occupancy codes required for the particular use of that space. Contract designers who only focus on the technical side of their work need to be more willing to work on the other facets of design. Especially if we are to move away from the idea that work needs to be done in a particular place like a traditional office.

So, this is what my intuition is telling me about the future of contract design—If designers working in other areas of design like hospitality or healthcare started only to design offices, we would not be moving offices into the future. Interior design that is only focused on a single intended use of the building or space will not have the longevity or the ability to be adapted to become useful in the future. Interior designers need to be human-centric and focus their design ideas on the best practices for keeping the people in these buildings healthy and safe.

I also see contract design continuing to use solid space planning techniques to best optimize the buildings interior. But we need to make better color choices that reflect the changing natural light coming into the building. We also need to specify and design furniture that encourages movement and physical wellbeing—incorporating artwork and choosing design aesthetics that will motivate people to want to be in any space.

For many professions, there will be requirements for specific equipment and furniture. Contract interior designers will need to adapt their design plans to those particular requirements. Designers need to understand and ask the right questions to create design solutions that meet those needs. This is what the true hallmarks are for the future of contract interior design.

The design profession will need talented designers who see our workspace and places evolve from the present to the future, where ideas and design plans come from various resources. Interior design is the driving force to change our outlook on life and work. Moving contract design in the direction that creates holistic and human-centric workplaces will be the best way forward regardless of how work is defined in our lifetime and beyond.

6 MRL FAVORITE OCCASIONAL TABLES FROM ACROSS THE LIBRARY

The following products represent 6 of our favorite products currently on My Resource Library. The products are listed in no particular order. Which is your favorite?

SWAY OCCASIONAL TABLE

KI

The Sway occasional table offers a visual complement to the Sway lounge collection, yet its universal appearance makes it perfectly adaptable to a range of other applications and furniture settings.



YAK

FROVI

Generous seating alongside sweeping lines and elegant styling, the Yak chair is perfect for engaging into an energetic meeting or simply taking 5 minutes to unwind into the deep foam seat. A completely customisable style, the generous Yak seat can be supported with a beautiful frame- available in a classic 4 leg, swivel 4 star or timeless sled design.

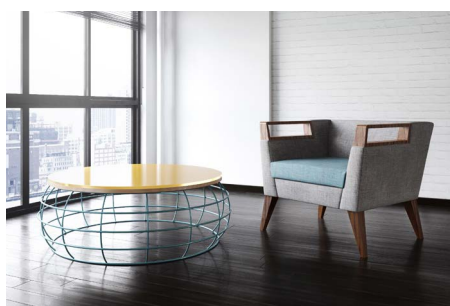

BROOKLYN OCCASIONAL TABLES

CORIANDER DESIGNS

Using a premium birch hardwood plywood layer creates additional warmth that helps to ground the design of the Brooklyn Coffee Tables and Side Tables. Constructed by welding curved steel rods to circular frames, Brooklyn Occasional Tables are distinctive pieces that can brighten up and add modern elegance to any space.



URBANA

GUNLOCKE

Sophisticated. Never stuffy. Substantial in scale. Refined in design. Award-winning Urbana freestanding lounge reflects careful tailoring and inviting comfort. Go for casual or dress it up. Versatile, mix-and-match options adapt to any space and need. It's progressive and timeless.

OCCASIONAL SIDE TABLES

MILDER FURNITURE

Side tables are the perfect accompaniment for any lounge or seating area and are available in a variety of sizes and shapes; the tables are 12" to 24" tall. Casters are optional. Side tables may include interior panels to form compartments (cubbies).



UNIVERSAL OCCASIONAL TABLES

NATIONAL

Create the look that matches your style and space, with Universal tables. With various sizes and shapes, our Universal side tables are the go-to solution for any space. White back painted glass tops offer a sleek and modern surface with a functional twist, as the glass can be used as a writeable surface.



Zip
Vinyl



STYLEX REVEALS THREE NEW FUTURE-PROOF SEATING COLLECTIONS



Underline



Cove



Click

Revitalizing Commercial Spaces with Adaptable Ease and Playful Sophistication

(Winter 2021- Delanco, NJ) - Commercial furnishings expert Stylex addresses the ever-evolving future of shared spaces with the launch of three American-made seating collections: Click, Underline, and Cove. From barstools, guest and lounge seating to conference and task chairs, each series supports a wide range of functions, environments, and aesthetics for absolute adaptability. Showcasing the best of simplistic and contemporary design, these latest launches bring a refreshing element of playfulness and comfort to commercial spaces.

“These introductions are inspired by a culmination of current and predictional trends,” explains Bruce Golden, CEO of Stylex. “This period like no other has produced uncertainty, but also a rare opportunity: the chance to truly rethink the way we work, learn, create, and collaborate. We are always looking forward to developing future-proof furnishings that will not only stand the test of time in terms of quality, but also in functionality. Click, Underline, and Cove do just that and more. They not only reflect and adhere to the hybridity of our spaces, but they respond to the need for adaptability and revitalization.”

Each seating series takes on an effortless, approachable design and color palette that makes spaces more lighthearted and comfortable, while serving every type of environment and application. Capable of filling an open office with seats

for all types of work styles, supporting a range of tasks in flexible workspaces, fostering creativity in learning environments, and beyond; the possibilities are truly endless. Serving as a bridge in promoting productivity through conversation and collaboration, these new releases exist to improve the spaces in which we work and gather. Customization options not only allow individual needs to be met ergonomically, but a plethora of mood-boosting color choices help awaken the senses, improving one’s focus and feelings of well-being.

A perfect blend of commercial quality, contemporary design, comfort, and flexibility, these series support and adapt to dynamic and evolving spaces of all kinds. Each having their own unique contributions to the built environment, Cove’s generous size and higher back provides privacy for heads-down focus in open-plan schemes as well as plenty of room to move freely and shift positions. The Click task chair offers a gimmick-free design that keeps to the basics, yet is intended to withstand high-use environments. While the Underline family of stools, guest and task chairs provides a single seating solution for the entire space in hospitality and workplace settings, it also creates a unified yet diverse design language through consistency in curvature and structure, allowing designers to effortlessly mix and match models, base types, colors, and materials.

Stylex's New Seating Introductions Include:

Click designed by Mark Kapka & Todd Yetman

The Click task chair harmoniously integrates form, material, and ergonomics to provide balance and comfort to the workplace. The sculpted s-shaped mesh back perfectly cradles the spine while the supportive outer plastic shell gives the chair a visually modern aesthetic. Playful and approachable, Click effortlessly moves with its user through full rocking motions and supports a broad range of seated postures through the use of one single adjustment to alter its height. From quick touchdowns to conference rooms and private offices alike, Click is the perfect complement to the evolving workplace. Available with and without arms, with a knit seat or upholstered seat, black or gray casters, and white, light grey, dark gray, black, or midnight colored plastic shell, Click is an essential piece for the modern office.



Underline designed by Lucidi Pevere

The Underline family of stools, guest, and task chairs bring a streamlined and cohesive, yet diverse and eclectic style to any environment. With a seat for every space, Underline's multipurpose offering provides visual and physical comfort through soft subtle curves and simplicity of form. True to its name, Underline's frame elegantly traces the outline of the seat, enhancing the play between the frame finish and upholstery of the seat. Designed at its core for hospitality and workplace settings, Underline underscores multiple mix and match options, with arm and armless stools and chairs in a plethora of base and finish options. Chairs are available with a metal sled, a metal or wood four-leg base, and a five-blade base. Stools are available with a metal sled, metal four-leg base, swivel wood base, and swivel pedestal. Finish options include 26 colorful VOC-free powder coats, polished aluminum, chrome, white oak, maple, walnut, and opaque black, offering designers the flexibility they need with the aesthetic they seek.



**FUTURE-PROOFING
WITH STYLEX**

Cove Lounge Chair by Brandon Walker

An extension of the popular Cove lounge chair, Cove is making a statement with its new higher backs. As much about comfort as form, Cove features a bowl-like seat that supports multiple postures—with room to spare for a laptop or cup of coffee. The high back provides visual and aural privacy, making personal meetings and focused work easier in open spaces, while the swivel base option and coordinating ottoman make it suitable for collaborative settings. Offering tremendous flexibility, Cove's additional fixed pedestal and sled base options further accommodate a variety in aesthetics and application. Bases may be powder-coated in an array of 26 VOC-free powder finishes to coordinate or contrast with the upholstery. Whether used as a focal lounge piece or grouped to support informal gatherings, Cove enhances appeal and usability within the environment. Cove is also Greenguard IAQ and Level 1 certified, demonstrating the possibilities of combining thoughtful design with innovative, green practices.



About Stylex

For more than six decades Stylex has designed and fabricated furnishings for both the workplace and healthcare, hospitality, and educational environments. We carefully consider the seating, tables, and lounge pieces we offer, balancing aesthetics, performance, and value. A desire to serve users ever-evolving needs has led us to collaborate with the field's top designers and engineers. Made from durable, sustainable materials that ensure their long life, our products add beauty and function to any space. For more information, visit at www.stylexseating.com.

STYLEX



By Michelle Warren

Michelle Warren is President of Catalyst Consulting Group, a firm specializing in providing strategic solutions to the commercial furniture industry to enhance their sales and positioning within the industry and distribution.

Michelle has been in the commercial furniture industry for over 25 years with experience on the dealer and manufacturer side of the industry. She has experience at the EVP, VP and National Sales Manager level for large and small manufacturers in addition to indepth understanding and experience in creating programs to target and selling to the Federal Government, State Government, Higher Education, and working with Cooperative Purchasing.

GSA selected her as 1 of 2 board members to represent industry on the Quality Partnership Council which she served on for almost 4 years. Additionally, she has represented the manufacture she worked for as a member of the Coalition for Government Procurement for over 4 years.

Because Michelle believes in the healthy building and how a building can affect employees, she is a Fitwel Ambassador.

Creating Sales strategies, strategic planning, 3-5 year road mapping, creating targeted marketing plans, distribution development, hiring reps, and training for reps and/or dealers have been numbered among her work.

She is known as a "serial networker" in the furniture industry and enjoys meeting people and making connections happen. If you want to connect with Michelle connect with her at Michelle@strategic-catalyst.com.



**Delving into the Public Sector:
Starting The New Year Off With a Bang!**

As we kick off a new year many of you probably have an annual ritual you do. When I googled some different new years' topics, I came across a lot of different traditions and actions people take. I also came across many quotes for the New Year. The first one I saw seemed appropriate for this article: A New Year brings new grace for new accomplishments.

Personally, do you make new years' resolutions? Do you select a word of the year? Do you create a vision board for the year? Whatever you do personally, I encourage you to do the same for your professional life. What is it you want to accomplish in 2022? The new year has brought you new grace so what are the new accomplishments you want to make?

For those of you who have been reading my articles in Delve over the past year, you know I am a planner. I love the plan with the knowledge that plans can and should change and fluctuate as unanticipated things happen (hello Covid!!) I also love goals. For me, goal setting is such an important part of everyday life. A good goal gives us something to reach for. Smaller goals allow for something to celebrate along the way to the Big Harry Audacious Goal (BHAG.) Goals can be long term or short term, and I encourage you to have both and many! What is the BHAG you want for your career? What are the short term or smaller goals you need to meet to get there?

In order for goals to be motivational, I believe you need to have the opportunity to celebrate small success along the way. So set the big goals that could be a promotion/new job/enhanced role or it can be a BHAG sales goal. Then focus in on some smaller more targeted goals like an account you want to penetrate or a contract you want to win that is a steppingstone to getting you to your BHAG. Think BIG! Believe BIG! David J. Schwartz PHD says in his book, The Magic of Thinking Big, "Those who believe they can move mountains, do. Those who believe they can't, cannot." Make your goals big BUT you need to believe you can achieve them!

What should you do after you have determined your goals for 2022?

- 1. Once you create your goals you need them to be visible to you regularly.** Print them out and put them up so you can see them. In the mirror in the bathroom when you get ready. In your office/workstation so you see them daily. Create a screen saver for your computer and/or phone so you can see them as often as possible. Human nature would show if you do not keep the goals front of mind you may veer off the path to the goal- I fondly refer to this as chasing the shiny objects (I do love me some shiny objects!)
- 2. Schedule time to revisit the goals and make sure you are on track to meet those goals** or allow for the opportunity to adjust due to unforeseen circumstances. Give yourself the grace you need to be flexible with these as there are things out of your control and some goals may get delayed, but that doesn't always mean that they should be removed completely- extend yourself the grace to extend the deadline for the goal.
- 3. Add new goals if circumstances have changed and you are moving in a new direction.** Add some small goals if you find that the ones you initially elected do not allow you to celebrate successes along the way.
- 4. Celebrate the successes!!** What is something that you can do to celebrate when you accomplish the small goals on the way to the BHAG? Plan the celebrations and do them. I have heard it said often that salespeople are "coin operated." I think to an extent this is true, but more so I believe we all appreciate rewards for a job well done. What reward do you want to give yourself for hitting that small goal? What is your reward for hitting the BHAG? The anticipation of the reward can be motivation enough for some of us to continue on days we are tired, or feel beat up, or don't win the most recent project/account/sale/contract we went after.

Set your goals.

Believe in yourself.

Show yourself grace.

Have an amazing 2022!

**ARCADIA WINS
GOOD DESIGN® AWARD**



Scenery Modular with Ledge and Wood Bridge, Popover Poufs

Arcadia's Scenery Modular Collection Wins 2021 Good Design® Award

Arcadia is pleased to announce that their Scenery Modular Collection is a 2021 GOOD DESIGN® award winner. Presented by The Chicago Athenaeum, together with The European Centre for Architecture Art Design and Urban Studies, Good Design remains the oldest and world's most recognized program for design excellence worldwide.

The museum received a record number of submissions this year, amounting to over 1,100 entrants from the world's leading manufacturers, industrial designers and graphic design firms from over 55 countries. Products range from consumer to commercial products across categories such as electronics, building products/materials, medical equipment, household products, sports and recreation, furniture, and office products, among many others. Awarded corporations represent some of the world's most visionary FORTUNE 500 and well-recognized private companies including Google, Dell, Coca-Cola, Netflix and Procter & Gamble.

"We are honored to be among this esteemed group of companies and congratulate Mark and David on this prestigious achievement," says Casey Journigan, Arcadia President. "The

recognition is a further testament to their talents and continues their legacy of creating award-winning designs." In addition to earning multiple GOOD DESIGN® awards, the team has also been behind several Best of NeoCon winning products, as well as recipients of the International Design Excellence Award and the coveted IDSA – Design of the Decade award.

Scenery Modular itself is a collection designed to allow multiple and varied interactions at once. The interior seating area offers spacious comfort for collaboration and casual conversation while a ledge around the exterior perimeter serves as a work surface or perching rest. Whether specified with the upholstered ledge feature, a wood bridge, or as traditional modular seating, Scenery creates the ultimate focal point where communication, socialization and productivity thrive.

Introduced in 2019, Scenery Modular has already earned a top-spot as one of Arcadia's most recognized products and now joins the 71st annual GOOD DESIGN® award roster.

**ARCADIA WINS
GOOD DESIGN® AWARD**



Mark & David, 5d Studio



Scenery Modular with Ledge and Armless Benches

About Arcadia

For more than thirty years, Arcadia has been dedicated to new product development and a breadth and depth of high quality seating and tabling solutions for large and small companies alike. Dynamic in environments ranging from corporate, educational, healthcare, hospitality and retail spaces to government institutions, airport and club lounges, and more, Arcadia's product collections are introduced each year at the NeoCon World Fair in Chicago and remain on display in its permanent showroom in Chicago's Merchandise Mart (Suite #340).

For more information, contact Tammie Alciatore, Director of Marketing, at 714.562.8200 or tammiea@arcadiacontract.com.

Photographs of the 2021 GOOD DESIGN Awards are available for download. For more details on the awarded winners, visit the Museum's website at www.good-designawards.com.

The Chicago Athenaeum (www.chi-athenaeum.org) is a global nonprofit education and research institute supported by its

members. Its mission is to provide public education about the significance of architecture and design and how those disciplines can have a positive effect on the human environment.

The European Centre for Architecture Art Design and Urban Studies (www.europeanarch.eu) is dedicated to public education concerning all aspects of the built environment - from entire cities to individual buildings - including the philosophical issues of arts and culture that ultimately give the final shape to design. A high emphasis exists on contemporary values and aesthetics, conservation and sustainability, and the theoretical exploration and advancement of art and design as the highest expression of culture and urbanism.

The GOOD DESIGN® is a trademark of The Chicago Athenaeum and The European Centre for Architecture Art Design and Urban Studies in the E.U.

If you can dream it, we can build it!

Visualising the creative process is a unique way to understand the artistry behind a design. Formaspace can take a product from concept to completion starting with a simple sketch.

Custom is the new standard at Formaspace.

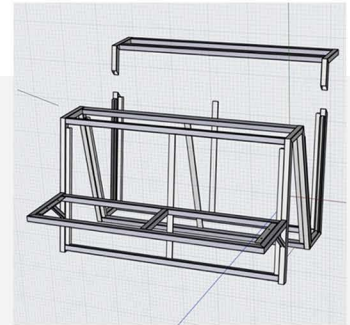
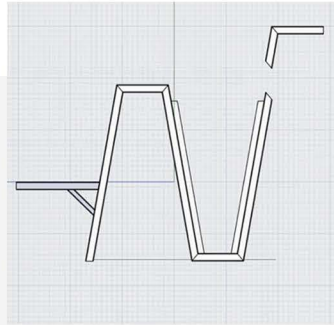
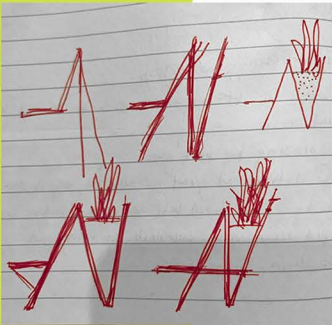

**STRIKING LIGHTING INSTALLATION BY LODES
TAKES CENTER STAGE IN NEW**

PENN STATE HEALTH MEDICAL FACILITY

**A Collaboration Between Lodes Distributor
JB Lighting Collection & CannonDesign**

Construction has just been completed on the new Hampden Medical Center, Penn State Health's first community hospital outside of its main Hershey, Pa. campus. CannonDesign, the creative force behind the project, worked closely with Lodes' exclusive North American lighting distributor JB Lighting Collection to realize a major focal point in the world-class facility: a remarkable installation featuring numerous A-Tube Nano pendants. The lighting display is prominently featured in "Flow," the awe-inspiring multi-story atrium at the heart of the building, which draws inspiration from the region's surrounding rivers, mountains, and meadows.



"We knew we wanted a sculptural light element which spoke to water, and presented multiple designs, one being Flow, featured in the atrium."

Kate St. Laurent who leads CannonDesign's dedicated Lighting Studio (CDLS).



Photo Credit: Halkin Mason Photography,
Courtesy of JB Lighting



“We also wanted a very bespoke look, which we knew might prove challenging given the project’s budget. That’s where JB Lighting Collection came into the picture. Our team presented a computational design to them, which featured the A-Tube Nano lights arranged according to the golden spiral ratio that is so prevalent in nature. The resulting installation is a dynamic, multi-layered work of art, which, thanks to Lodes’ versatile and modular standard products, we were able to achieve in a timely manner and at a fraction of the cost,” she concludes. Blair Hutkin, co-founder of JB lighting Collection, adds, “The micro recessed canopies in A-Tube Nano were integral in meeting the demands of this complex configuration. They afforded the use of remote drivers—keeping costs down by having pendants share drivers—and eased installation with simple height adjustments and fine-tuning. With their subtle, low profile silhouette, the A-Tube Nano pendants seem to nearly ‘disappear’ into the ceiling, allowing the focus to remain on the visually impactful form of the overall structure.”

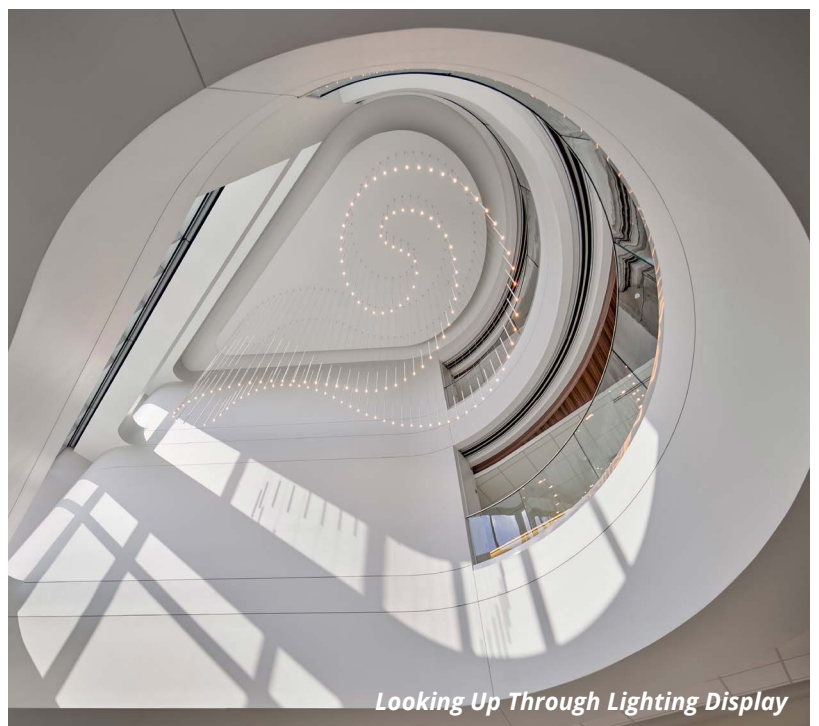

COVER STORY

The A-Tube Nano is one design among many within Lodes' assortment of Cluster Suspension lights. The range offers endless possibilities for bespoke looks using in-stock standard products. Users can select pendant type, finish, size, color, and canopy type to create single light pendants, multi-light pendants, groupings, and multi-layered installations. Lodes offers a new [product configurator](#) to simplify creating a bill of materials, as well as 2D and 3D design files to easily incorporate the pendants into design plans.



About Lodes

Balancing technical know-how and the best Made in Italy design, Venice-based Lodes has been designing and producing lighting solutions for interiors and exteriors since 1950.

Originating in founder Angelo Tosetto's passion for glass and informed by continuous technological research, the company has evolved into one of Europe's leading designers and manufacturers of decorative lighting, currently present in 90 markets worldwide.

Today, Lodes represents a three-generation evolution from pure passion to brilliant architectural solutions, creating light sources that fuse contemporary design and innovative technology with materials of the highest quality, scrupulously developed with the best processing techniques.

About JB Lighting Collection

JB Lighting Collection is the result of the partnership of lighting industry veterans Josie A. Anthony and Blair H. Hutkin. Combining years of experience and expertise, their collaborative efforts are focused on curating and distributing the finest quality lighting products in one place: [JBLightingCollection.com](#). The company was created to inspire, supply and support designers, architects, high-end retailers and sophisticated residential customers who desire to incorporate art in the form of distinctly refined lighting into all aspects of design.



By Ashley Blevins

Ashley Blevins is the Director of Sales for GMi Companies who is a manufacturer of the brands Ghent, Waddell, and Vividboard. After spending over a decade in marketing, specializing in dealer relations, Ashley has been responsible for expanding the national sales footprint for the GMi family of brands.

Ashley is a certified presenter of CEU's and travels the nation providing presentations that train and educate dealers, architects, and designers on skills to educate their clients and close the sale

Ashley has found her passion in serving customers by providing value, earning trust, and turning customers into partners. Her philosophy for marketing and sales revolves around embracing change, trial and error, thinking strategically and using data to drive your next move. In her free time, you can find her enjoying the country air with her family or waving her Terrible Towel on Sundays.

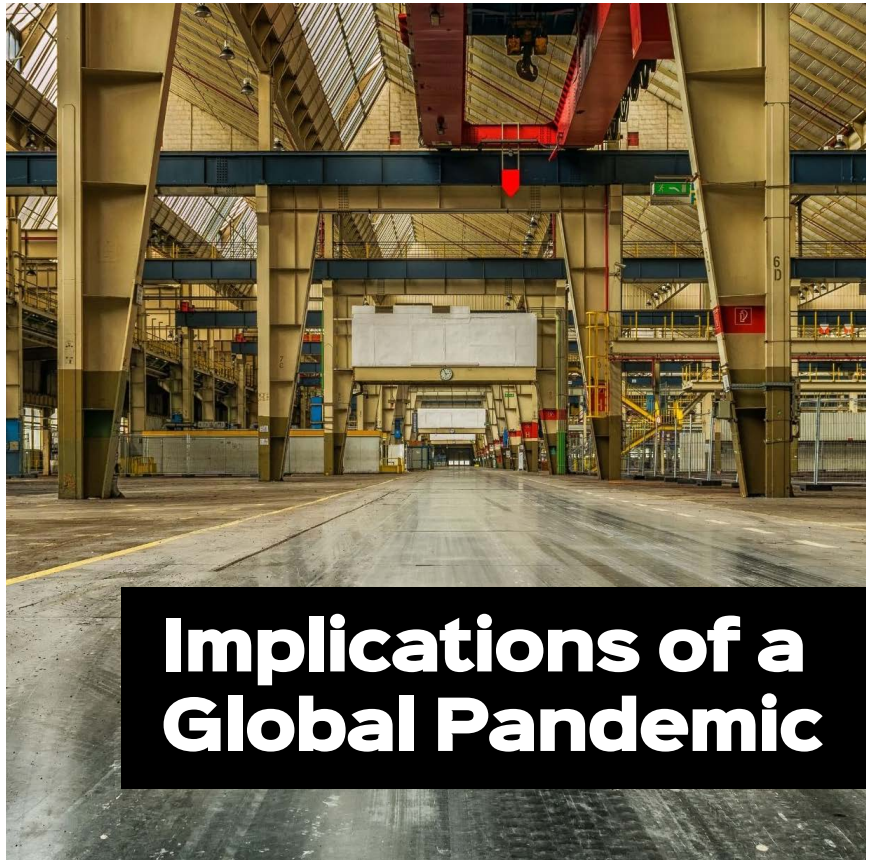

Implications of a Global Pandemic

Unlike historical recessions, the COVID pandemic has caused unique and chaotic changes to how we conduct business today. In the next few months, I'll be breaking down why this pandemic is so different than historical economic recessions. We will dive into what those differences are while focusing the lens on manufacturers in our industry.

These discussions will be broken into different categories like supply chain, inventory and materials shortages, freight and logistics, and the big talking point: labor shortages. Discussions will focus on providing insights into how these key areas are affecting the manufacturers you rely on for your business.

To start, I'd like to share some historical manufacturing stats in the USA. In 1979, the US had around 19.7 million jobs in manufacturing, this was peak employment. Throughout the decades since, there has been a steady decline, specifically as we reached the 2000's. Then, manufacturing jobs started to bottom out in 2009. There are a few leading indicators to why manufacturing woes are at an all-time high:

1. Manufacturers began to optimize operations by implementing technology solutions to increase efficiencies, revenue, and profitability. The impact of implementing technology solutions resulted in a reduction of employees.
 - U.S. manufacturers now produce three and a half times more output per worker hour than they did in 1979.
2. A multi-generational shift away from trade schools and manufacturing jobs became the norm. As noted from the indicator above, people were fearful their job would be reduced by technology. The outcome was finding new skills, new type of work and making sure their children did the same.
 - How many Millennials grew up being told to go into manufacturing and

trade schools? College was the expected course for success.

- Despite the population growth, the same number of people worked in manufacturing jobs in 2018 as in 1949.

3. Manufacturing jobs began moving offshore and away from American soil due to low labor wages and overhead energy costs.

As we look at these three leading indicators it is clear manufacturers were struggling with labor woes for many years prior to the pandemic. So, when the avalanche of change was thrust upon us, we were hurt tenfold on labor. Then, new problems arose in supply chain, freight and logistics, and inventory control. Why? During most recessions, you are dealing with a specific country who is experiencing an economic situation. The COVID pandemic is unique in that the global economy was affected and ultimately shut down for periods of time. The global aspect of this pandemic is what is so unique and will have a lasting impact on the world. The global implications unearthed problems we never had to worry about before, and new problems from what most recessions uncover.

From a manufacturers point of view the first few months of the pandemic were rather unpredictable and quite honestly frantic. We were backed into situations we could not prepare for. Decisions were made on inventory like when do you stop spending money on materials to produce products while sales were drying up? How do we keep materials in house when suddenly lead times go from 1 week to 30 weeks? And most importantly how do we keep employees safe from COVID and ultimately a furlough.

We were tasked with being agile, having to pivot 180 degrees from original plans at a second's notice. For those that persevered, it was not from dumb luck, it was with a whole lot of blood, sweat and tears and honestly plenty of mistakes. Heck, we are still learning, and it is far from over. Things continue to shift and change; we take one step forward and two steps back almost daily.

As an industry the major impacts to manufacturers can be summarized into 4 major categories:

- 1. Supply Chain and Material Shortages**
- 2. Inventory Control**
- 3. Freight & Logistics**
- 4. Labor**

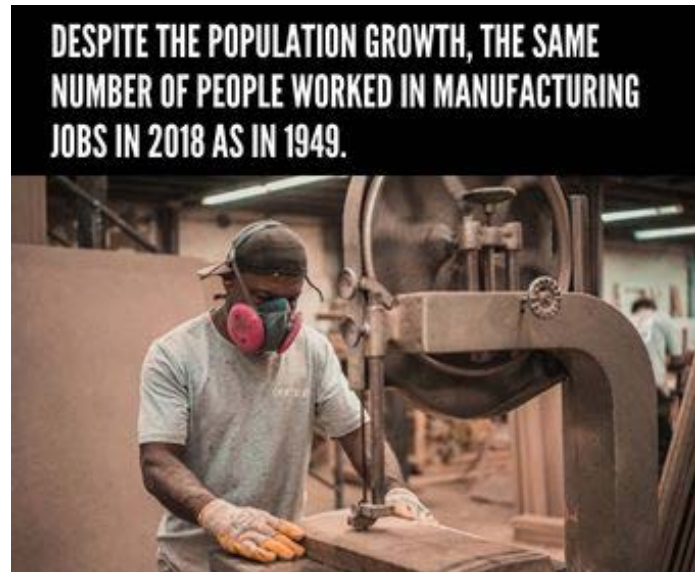

You might be thinking now is not the time to be in manufacturing... However, we do have a lot to be optimistic about as we look ahead. Manufacturers have made improvements to processes and technology at a speed we have never seen before. Innovation flourished, demand is at an all-time high, commercial construction trends are moving into recovery and the US and Global economies are expecting to boom in the remaining decade. **When you look at various reports for manufacturing in the US, the outlook for 2022 is extremely optimistic, we have a lot to look forward to:**

- **Product Demand flourishes**
- **Manufacturing sales are expected to increase**
- **Production growth continues to rise**
- **Full-time Employment will continue to be at an all-time high for manufacturing jobs**
- **Employee wages are record high and will continue to rise**
- **Capital spending expected to rise over the next 12 months**

So, as we explore each of these subjects in coming months, I hope we can provide a valid look into the world of manufacturing, the highs, and lows, and a glimpse to what the future holds. We are all in this together and if there is one thing I know, this industry supports and loves their manufacturers.

MRL EXPANDS ITS DEALER SERVICES TEAM

Hires Heidi Fields to Lead Dealer Sales & Development

My Resource Library (MRL), software leader in the Contract Furniture Industry, officially announced the hiring of Heidi Fields of Muscatine, Iowa as lead Dealer Sales Representative.

Heidi has over 20 years of experience in the office furniture industry, with the majority of her time spent in management. She has worked with industry leaders such as Allsteel and HON focusing on marketing, national sales training, strategic accounts sales, and business development program leadership.

Recently, she also gained experience within the community of independent reps as National Sales Director for Thinkspace/Hushoffice.

In her position at MRL she will serve a key role in business development by creating and maintaining relationships across their national dealer network. Develop and deploy a sales plan to further the growth of the MRL brand and dealer customer base.

She will also focus on proactively identifying and assessing dealer needs to enhance customer satisfaction across MRL's dealer department. The ultimate goal being to increase account retention and strengthen MRL's dealer relations nationwide.

"We are thrilled to welcome Heidi to the MRL team," remarked Jim Palmitier, President of My Resource Library. "Her substantial industry experience along with her commitment to great customer service is a perfect fit for MRL and our mission for the future."

An Iowa farm girl at heart, Heidi enjoys travel, working out, yoga,

baking, and volunteering. Heidi and her husband of 8 years, Kevin, enjoy spending time in Vero Beach, FL and visiting various wine regions, with a special love of Sonoma, where they were married at a winery. Together they have 5 grown children and enjoy spending time with their family, friends and mini-Schnauzer, Cocoa. Heidi's theory in life revolves around YNK – "you never know". Drink the wine, take the trip, try something new, have the dessert, hug your loved ones – because you never know what tomorrow might bring.

She officially joined the MRL team on January 10th and is already hitting the ground running!



Heidi Fields, Dealer Sales, My Resource Library
heidi@myresourcelibrary.com

KEEPING CONNECTED

With the challenges that 2020 and 2021 brought, it is more important than ever to "Keep Connected" to our clients, friends and colleagues. We have been simply inspired by all of the innovative ways our Rep Group friends have found to do just that! The pandemic hasn't slowed them down one bit, and relationships are still at the center of their strategy.

In the "Keeping Connected" section of Delve Magazine, we will highlight inspirational snapshots of what our Rep Group partners are up to, and how they are finding innovative ways to stay connected to their clients.

We hope you enjoy this new feature, and are inspired as much as we are!



Deb and Kim

DCA (Debra Calkins Associates)

Debra Calkins Associates, Kim Campbell and Deb Calkins, participated in three local IIDA events, San Francisco, Oakland and Sacramento. We also sponsored the NEWH San Francisco/Bay Area Top Interior Design firms event. It was

**KEEPING
CONNECTED**

DCA continued..

great to show our new products from Arcadia, Arden Studio, Encore, Frovi, Modern Nature Design and Segis. We reconnected with our colleagues, re-energized our furnishings spirit.

DCA-Reps.com

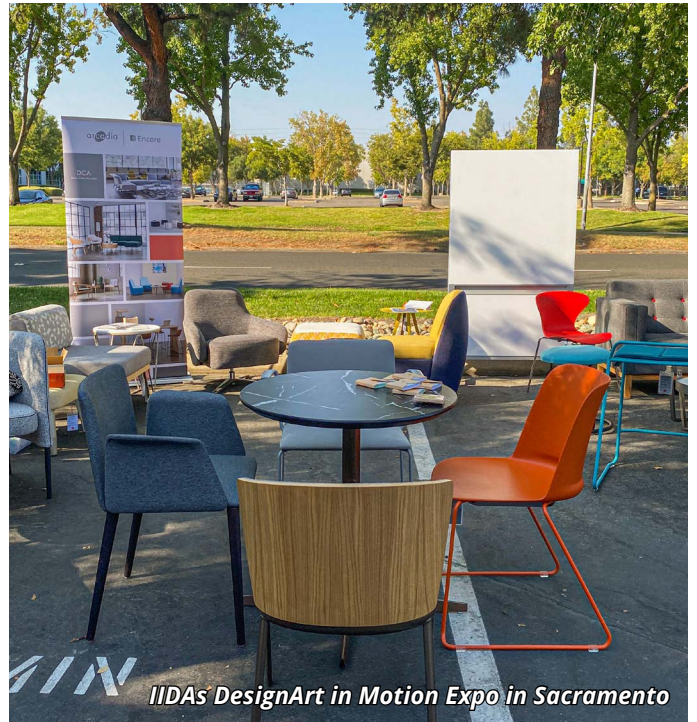

**KEEPING
CONNECTED**



Reinbeer Holiday Gifts



Gift Wrap Event 2 - Lauren



Gift Wrap Event - Lauren

BLG

Since 2004, the Bruce Longhino Group has represented the finest contract furniture and accessory lines in the country. Our expertise, experience and reputation have been instrumental in establishing distribution channels to market our lines to end users, the design community and our dealership partners.

December Gift Wrap Event with BLG

December BLG events with Lauren Carbaugh. Lauren covers Central Ohio for BLG. She co-hosted a Gift Wrap Event with some fellow reps from various A&D industries. They provided wrapping paper, tags and bows for designers to knock out their wrapping before the holidays. It is a great way to get your wrapping completed without any distractions or spying eyes! Lauren also provided some fun "Reinbeer" giveaways to keep your "Spirits Bright"!

BLGreps.com

delve^{MRU}
JAN2022V22

Published by
MYRESOURCELIBRARY.COM